

Fiche technique :

# **MRT 2145 EASY T4 S1 360°**

---



Capacities		Métrique	Impérial
Max. capacity	Q	4500 kg	9921 lbs
Max. lifting height	h3	20.6 m	67 ft 7 in
Max. Reach	l4	17.9 m	58 ft 9 in
Weight and dimensions			
Ground clearance	m4	0.32 m	1 ft 1 in
Wheelbase	y	2.75 m	9 ft
Length to face of forks	l2	6.59 m	21 ft 7 in
Length of frame	l14	4.71 m	15 ft 5 in
Overall length (with forks)	l1	6.59 m	21 ft 7 in
Overall width	b1	2.5 m	8 ft 2 in
Overall width with stabilisers extended	b7	4.98 m	16 ft 4 in
Overall height	h17	3.02 m	9 ft 11 in
Overall cab width	b4	0.95 m	3 ft 1 in
Tilt-down angle	a5	107 °	107 °
Tilt-up angle	a4	10 °	10 °
Forks length / width / section	l / e / s	1200 mm x 150 mm x 50 mm	47.244 in x 5.906 in x 1.969 in
Internal turning radius (over tyres)	b13	4.62 m	15 ft 2 in
Overall weight		14530 kg	32033 lbs
Wheels			
Tyres type		Pneumatic	Pneumatic
Stabilisers			
Stabs Type		Wing Type	Wing Type
Controls with stabs		Stabs Commands Individual or Simultaneous	Stabs Commands Individual or Simultaneous
Engine			
Engine brand		Perkins	Perkins
Engine norm		Stage IV / Tier 4 Final	Stage IV / Tier 4 Final
Engine model		854F-E34TA	854F-E34TA
I.C. Engine power rating / Power (kW)		102 Hp / 75 kW	102 Hp / 75 kW
Max. torque / Engine rotation		430 @ 1200 tr/min	430 @ 1200 tr/min
Number of cylinders - Capacity of cylinders		4 - 3400 cm <sup>3</sup>	4 - 207.48 in <sup>3</sup>
Injection		engine Injection direct	engine Injection direct
Engine cooling system		Water	Water
Battery / Batteries capacity		12 V / 180 A	12 V / 180 A
Drawbar pull (Laden)		7900 daN	7900 daN
Transmission			
Transmission type		Hydrostatic	Hydrostatic
Number of gears (forward / reverse)		2 / 2	2 / 2
Max. travel speed (may vary according to applicable regulations)		37 km/h	23 mph
Parking brake		Automatic negative parking brake	Automatic negative parking brake
Service brake		Hydraulic	Hydraulic
Hydraulics			
Hydraulic pump type		Gear Pump	Gear Pump
Hydraulic flow		115 l/min	115 l/min
Hydraulic Pressure		270 Bar	19 PSI
Tank capacities			
Engine oil		8 l	1.76 gal
Hydraulic oil		150 l	33 gal
Fuel tank		130 l	28.6 gal
Diesel Exhaust fluid (AdBlue® type)		19 l	4.18 gal
Noise and vibration			
Noise at driving position (LpA)		79.7 dB(A)	79.7 dB(A)
Noise to environment (LwA)		105 dB(A)	105 dB(A)
Vibration to whole hand/arm		< 2.50 m/s <sup>2</sup>	< 2.50 m/s <sup>2</sup>
Miscellaneous			
Controls		2 Joysticks	2 Joysticks
Safety cabin homologation		Cab ROPS - FOPS Level 2	Cab ROPS - FOPS Level 2
Attachment recognition system (E-Reco)		Standard	Standard

## Schémas d'encombrement

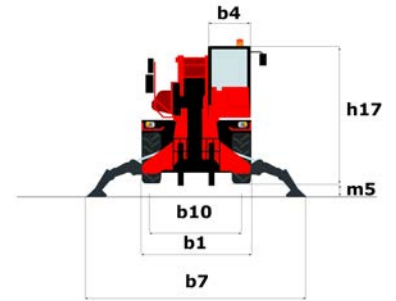
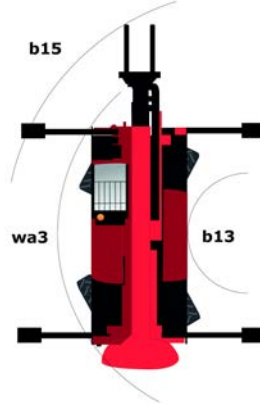
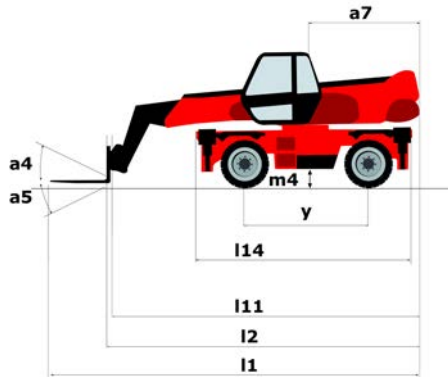

Autres données		Métrique	Impérial
Overall length (with forks)	l1	6.59 m	21 ft 7 in
Length to face of forks	l2	6.59 m	21 ft 7 in
Length of frame	l14	4.71 m	15 ft 5 in
Wheelbase	y	2.75 m	9 ft
Ground clearance	m4	0.32 m	1 ft 1 in
Counterweight offset (turret at 90°)	a7	2.7 m	8 ft 10 in
Tilt-up angle	a4	10 °	10 °
Tilt-down angle	a5	107 °	107 °
Overall length at stabilisers	l12	4.35 m	14 ft 3 in
Outer turning radius (with forks)	b15	4.62 m	15 ft 2 in
Overall width	b1	2.5 m	8 ft 2 in
Overall width with stabilisers extended	b7	4.98 m	16 ft 4 in
Overall cab width	b4	0.95 m	3 ft 1 in
Overall height	h17	3.02 m	9 ft 11 in

# Abaques

Load Chart metric

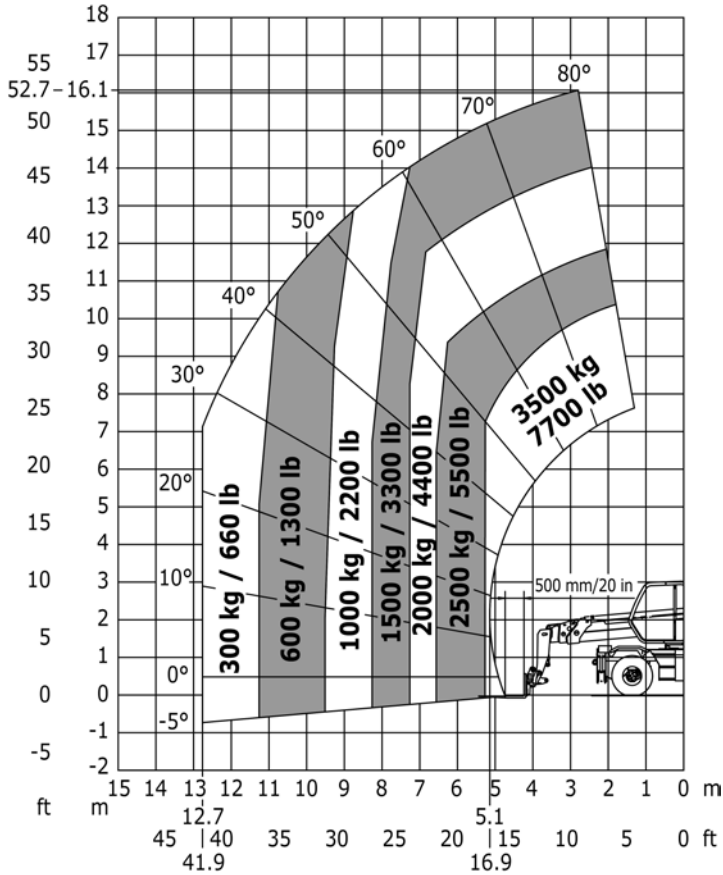

Machine on tyres with forks Metric

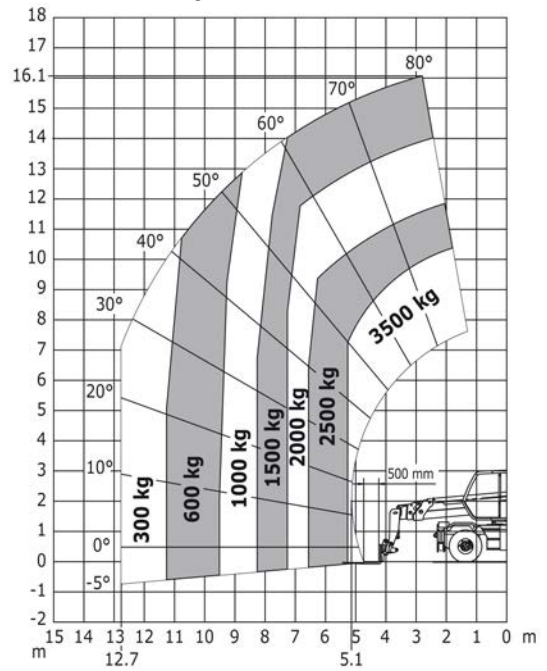

Rotation on lowered stabilisers with 1000 kg platform Metric

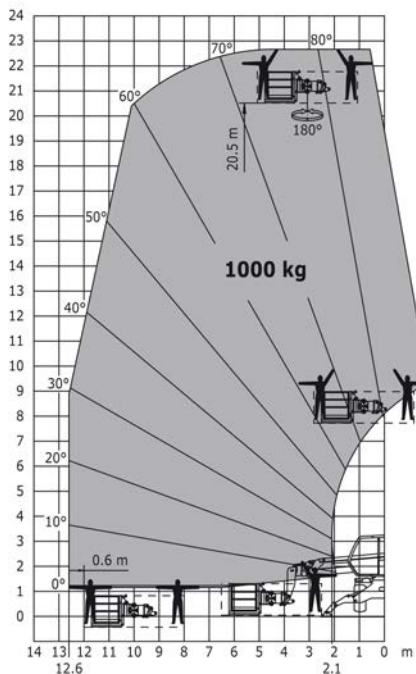

Rotation on lowered stabilisers with 1500 kg jib Metric

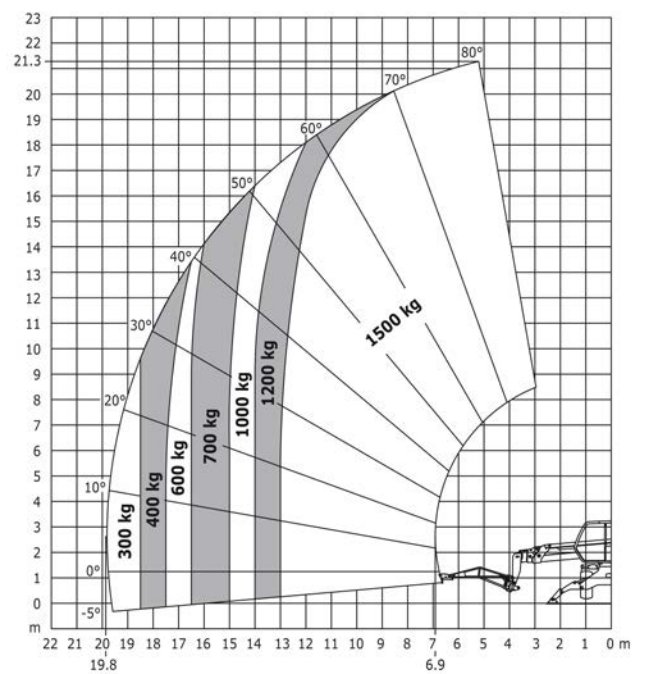

Rotation on lowered stabilisers with 365 kg

Rotation on lowered stabilisers with forks

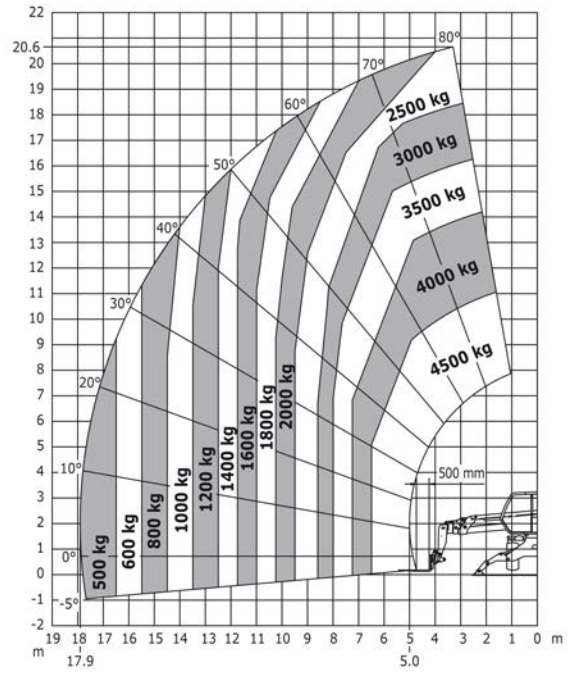
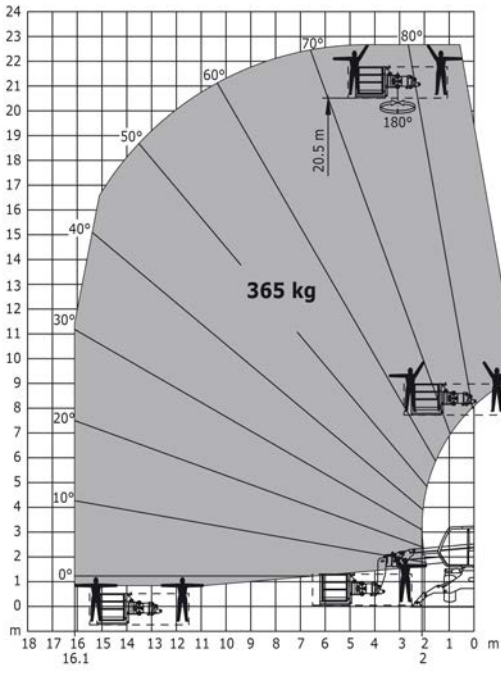

Rotation on lowered stabilisers with winch  
5000 kg Metric

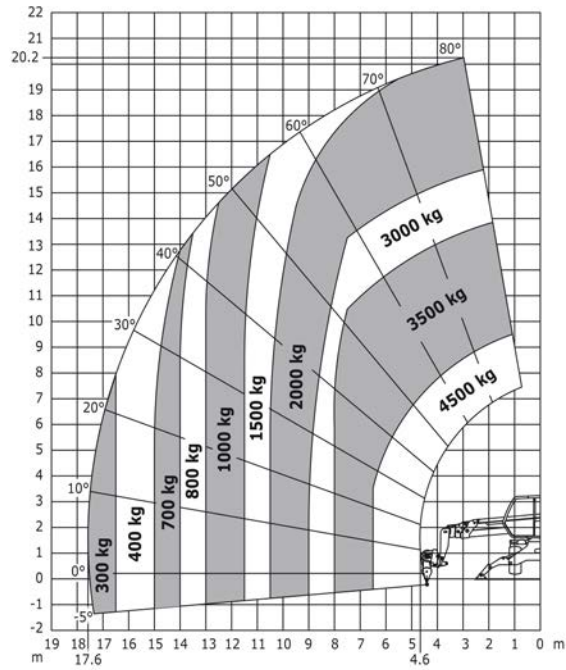

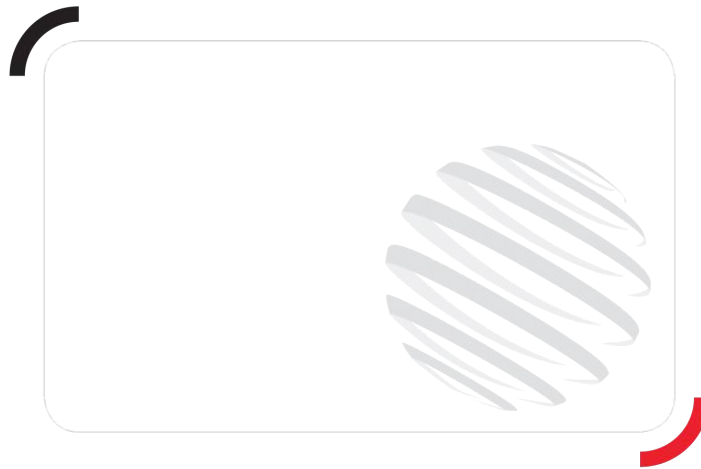

Siège Social

430 rue de l'Aubinière - 44150 Ancenis Cedex - France

Tel: +33(0)2 40 09 10 11 - Fax: +33 (0)2 40 09 10 97

[www.manitou.com](http://www.manitou.com)



Cette publication présente le descriptif des versions et possibilités de configuration des produits Manitou qui peuvent différer en équipement. Les équipements présentés dans cette brochure peuvent être de série, en option, ou non disponibles suivant les versions. Manitou se réserve le droit, à tout moment et sans préavis, de modifier les spécifications décrites et représentées. Les spécifications portées n'engagent pas le constructeur. Pour plus de détails, contactez votre concessionnaire Manitou. Document non contractuel. Présentation des produits non contractuelle. List des spécifications non exhaustive. Les logos ainsi que l'identité visuelle de l'entreprise sont la propriété de Manitou et ne peuvent être utilisés sans autorisation. Tous droits réservés. Les photos et schémas contenus dans la présente brochure ne sont fournis qu'à des fins de consultation et à titre indicatif.

MANITOU BF SA - Société anonyme à conseil d'administration - Capital social : 39 547 824 euros - 857 802 508 RCS Nantes